

SIZE : 50

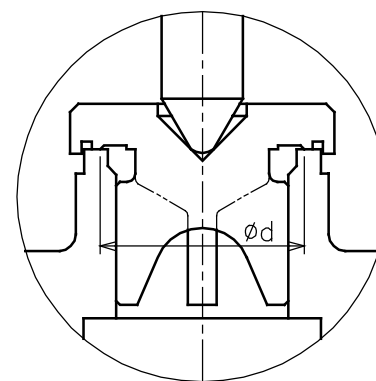

SIZE : 32~50

No.	NAME OF PARTS	部 品 名	MATERIAL	材 質
1	VALVE BODY	ホンタイ	STAINLESS STEEL	SCS 13
2	SPRING CASE	バネケース	"	"
3	CAP	キャップ	"	"
4	DISC	ベンタイ	"	"
5	STEM	ステム	"	SUS 304
6	SPRING SEAT	バネウケ	"	"
7	BOTTOM SPRING SEAT	シタバネウケ (50A)	"	"
8	ADJUSTING SPRING	チョウセツバネ	"	"
9	ADJUSTING SCREW	チョウセツネジ	"	"
10	LOCK NUT	チョウセツLナット	"	"
11	GASKET	ガスケット	PTFE	PTFE
12	NAME PLATE	ネームプレート	ALUMINIUM ALLOY	A 1050 P

DIMENSIONS (mm)

SIZE	L1	L2	d	H	A	B
15	30	36	14	85	1/2	1/2
20	35	40	19	89	3/4	3/4
25	40	46	23	93	1	1
32	50	54	32	115	1 1/4	1 1/4
40	55	60	40	120	1 1/2	1 1/2
50	65	73	50	152	2	2

CODE 製品記号	ADJUSTING RANGE MPa
SL40-D1	0.05 ~ 0.1
SL40-D2	OVER 0.1 TO 0.2
SL40-D3	OVER 0.2 TO 0.5
SL40-D4	OVER 0.5 TO 1.0

SPECIFICATIONS(仕様)	
FLUID(流体)	
SET PRESS.(設定圧力)	MPa
TEMP.(温度)	℃

SL-40 TYPE SAFETY RELIEF VALVE SL-40 型 安全逃し弁	DRAWING 製 図	S. Hosokawa
	CHECK 検 査	T. Komatsu
	DATE 日 付	2014-11-5
	NOTE	

APPROVED DWG.No. 出 図 番 号	 VENN CO., LTD. 株式会社
DWG.No. SL40-61F-P	