

No.	NAME OF PARTS	部 品 名	MATERIAL	材 質
1	VALVE BODY	ホンタイ	CAST IRON	FC 200
2	SPRING CASE	バネケース	"	"
3	CAP	キャップ	"	"
4	SEAT RING	ベンザ	BRASS	C 3604 B
5	DISC	ベンタイ	"	"
6	STEM	ステム	STAINLESS STEEL	SUS 304
7	BOTTOM SPRING SEAT	シタバネウケ	CAST IRON	FC 200
8	TOP SPRING SEAT	ウエバネウケ	"	"
9	ADJUSTING SPRING	チョウセツバネ	SPRING STEEL	SAE9254 or SUP 9
10	ADJUSTING SCREW	チョウセツネジ	BRASS	C 3604 B
11	LOCK NUT	チョウセツL ナット	ROLLED STEEL	SS 400
12	STUD, NUT	スタッド, ナット	"	"
13	PLUG	プラグ	"	"
14	PLUG	プラグ	CARBON STEEL	SWCH 10R
15	PLUG	プラグ	STAINLESS STEEL	SUS 304
16	O RING	O リング	SYNTHETIC RUBBER	NBR
17	GASKET	ガスケット	NON-ASBESTOS	ノンアスベスト
18	GASKET	ガスケット	"	"
19	GASKET	ガスケット	"	"

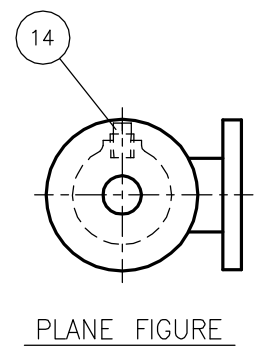
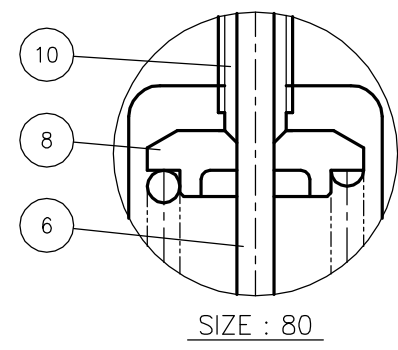
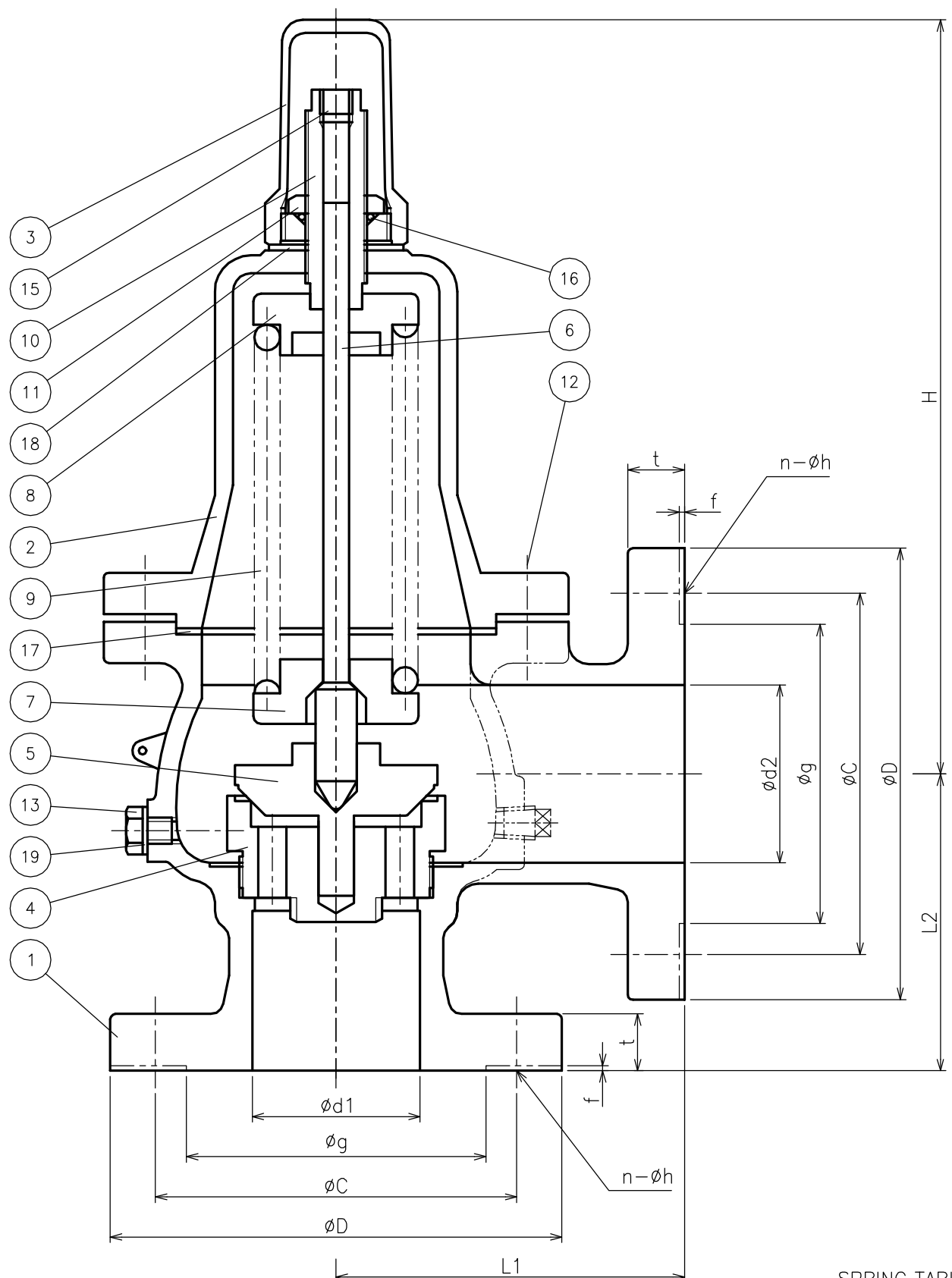

DIMENSIONS (mm)

SIZE	FLANGE CODE	L1	L2	H	d1	d2	D	C	g	t	f	n	h
65	JIS 5K	131	111	291	65	69	155	130	110	18	2	4	15
	JIS 10K	135	115	291	65	69	175	140	116	22	2	4	19
80	JIS 5K	141	121	371	80	84	180	145	121	18	2	4	19
	JIS 10K	145	125	371	80	84	185	150	126	22	2	8	19

SPRING TABLE. (PARTS No.9)

WIRE DIAMETER (mm)	MATERIAL
OVER 4.5 TO 12	SAE9254
OVER 12	SUP 9

SPECIFICATIONS(仕様)	
FLUID(流体)	
SET PRESS.(設定圧力)	MPa
TEMP.(温度)	℃

CODE 製品記号	ADJUSTING RANGE (MPa)	
	SIZE : 65	SIZE : 80
SL24E-B1	0.035 ~ 0.2	0.035 ~ 0.2
SL24E-B2	OVER 0.2 TO 0.7	OVER 0.2 TO 0.5
SL24E-B3	OVER 0.7 TO 1.0	OVER 0.5 TO 0.8
SL24E-B4	---	OVER 0.8 TO 1.0

SL-24E TYPE
RELIEF VALVE

SL-24E 型
レリーフ弁

APPROVED DWG.No.
出 図 番 号

DWG.No.

SL24E-02H-P

DRAWING 製 図	H. Sasaki
CHECK 検 査	Y. Yonekura
DATE 日 付	2015- 8- 5
NOTE	

