

NO.	NAME OF PARTS		MATERIAL	QTY	REMARKS	NO.	NAME OF PARTS		MATERIAL	QTY	REMARKS
1	VALVE BODY	ホンタイ	CAC 406	1		4					
2	NOZZLE (A)	Aノズル	CAC 406C	1	15~25mm	5					
			CAC 406	1	32, 40mm	6					
3	NOZZLE (B)	Bノズル	CAC 406C	1	15~25mm	7					
			CAC 406	1	32, 40mm	8					

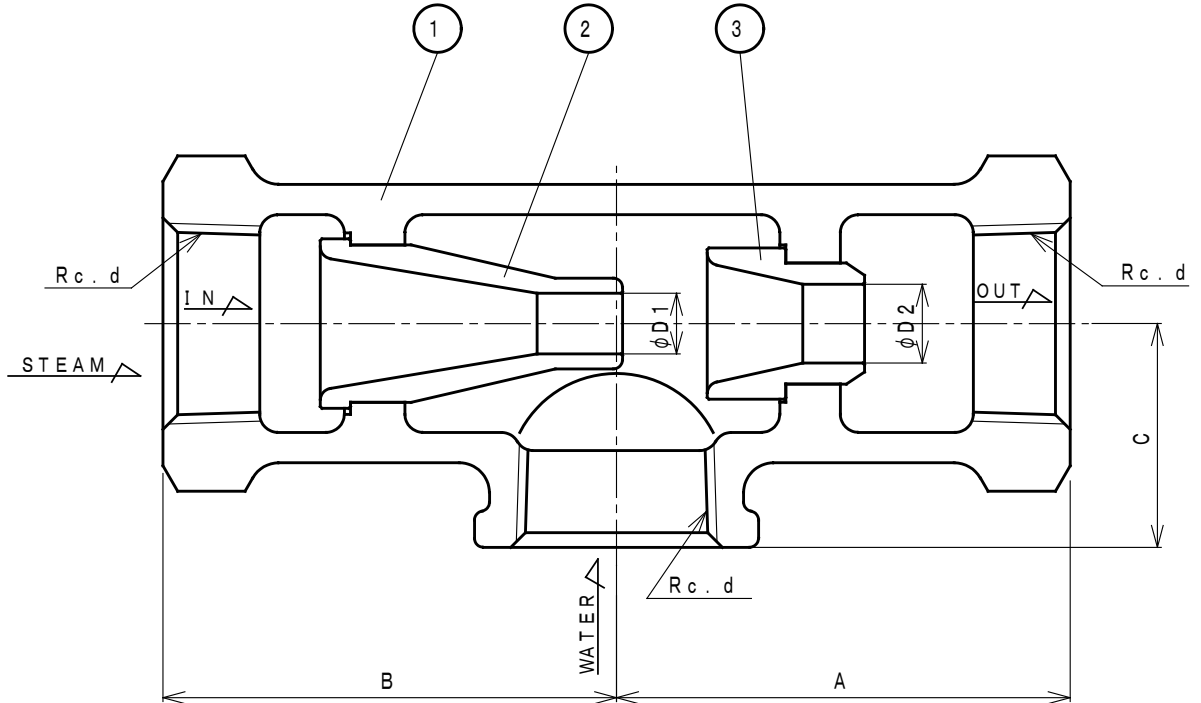

DI MENS I ONS ( mm )

SI ZE	d	A	B	C	D1	D2
15	1/2	54	54	25	5	8
20	3/4	62	63	31	7.6	12
25	1	75	75	37	8.2	13
32	1 1/4	93	91	45	11	15
40	1 1/2	110	109	50	15	18

仕様

SPECI F I C A T I O N S

適用流体 APPLICABLE FLUID	蒸気 STEAM
適用圧力 APPLICABLE PRESSURE	最高. 0.7 MPa MAX.
耐圧試験 PRESSURE TEST	水圧にて 1.4 MPa HYDRAULIC
発音限界温度 WARNING SOUND TEMPERATURE LIMIT	66℃

製品記号 CODE
QH1-F

QH-1 TYPE NOISELESS HEATER QH-1 型 サイレンサ	APPROVED 承認	CHECK 検	DRAWING 製図
	<i>[Signature]</i>	<i>[Signature]</i>	T. KOGURE
	DATE 日付	2005-02-25	
	NOTE	CAC 406	
APPROVED DWG. NO. 出図番号			
DWG. No. 原図番号			
QH1-01H-P			
SER. No. 管理番号			
	 <b>VENN CO., LTD.</b> 株式会社		