

No.	NAME OF PARTS	部 品 名	MATERIAL	材 質
1	BODY	ホンタイ	STAINLESS STEEL	SCS 13A or SCS13
2	COVER	カバー	〃	SCS 13A or SCS13
3	NET	ネット	〃	SUS304
4	STOPPER	ストッパー	〃	〃
5	PLUG (SIZE125~150)	プラグ	〃	〃
6	PLUG (SIZE80~150)	プラグ	〃	〃
7	PLUG	プラグ	〃	〃
8	O RING	Oリング	SYNTHETIC RUBBER	NBR
9	BOLT	ボルト	STAINLESS STEEL	SUS304
10	COVER HOLDER	カバーオサエ	DUCTILE CAST IRON	FCD 450
11	EYE BOLT (SIZE125,150)	アイボルト	STAINLESS STEEL	SUS304
12	NUT (SIZE125,150)	ナット	〃	〃

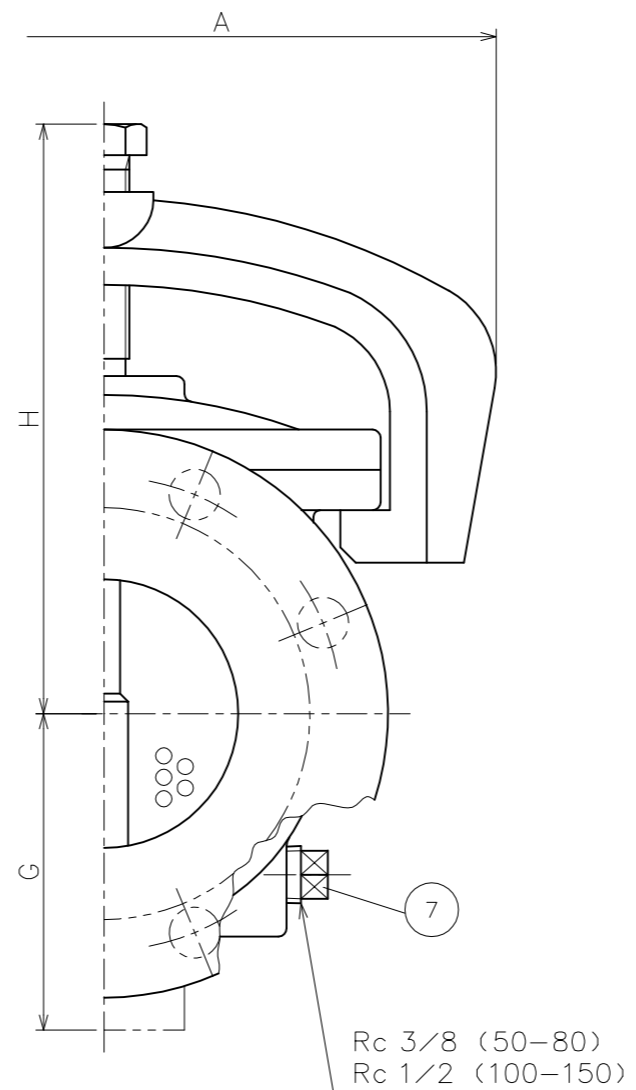
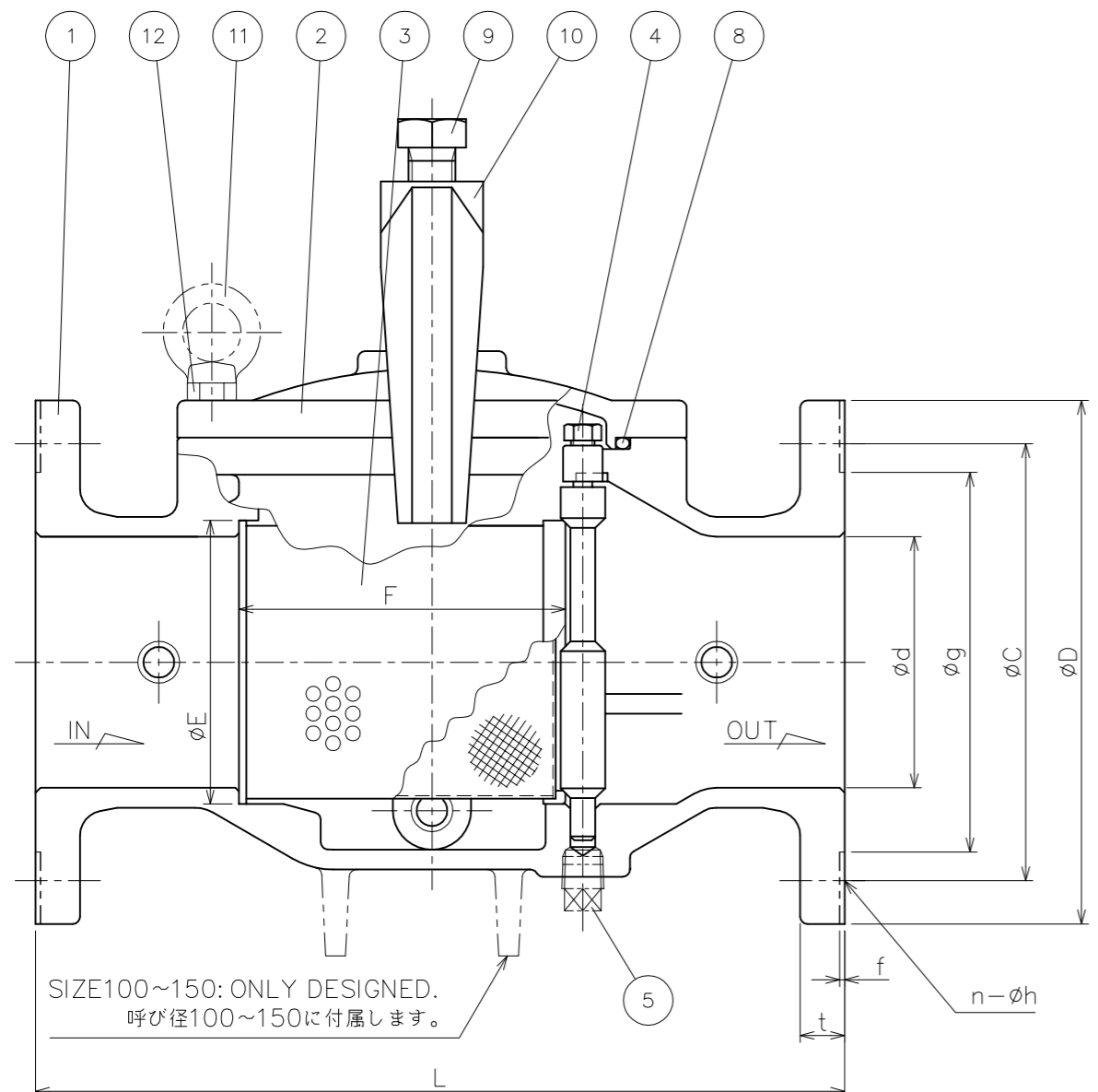

DIMENSIONS (mm) FLANGE CODE: JIS 10K

SIZE	L	D	C	g	d	t	f	n	h	H	G	A	E	F	MASS (kg)
50	220	155	120	96	50	16	2	4	19	144	-	200	58.5	75	10.0
65	270	175	140	116	65	18	2	4	19	161	-	230	74.5	93	15.5
80	290	185	150	126	80	18	2	8	19	200	-	280	87.5	115	20.5
100	350	210	175	151	100	18	2	8	19	233	130	300	112.5	136	29.0
125	390	250	210	182	125	20	2	8	23	259	140	370	138.5	169	49.0
150	440	280	240	212	150	22	2	8	23	275	165	380	163.5	197	64.5

SPECIFICATIONS (仕様)			
SIZE	50~100	125	150
APPLICABLE PRESS. (MPa) (適用圧力)	MAX 1.0	MAX 0.75	MAX 0.5
APPLICABLE TEMP. (°C) (適用温度)	5~90		

CODE 製品記号	MESH メッシュ
KT3A-D	20
KT3A-D	40
KT3A-D	60
KT3A-D	80
KT3A-D	100

KT-3A TYPE STRAINER	DRAWING 製 図	R. Yada
	CHECK 検 査	S. Hosokawa
KT-3A 型 ストレーナ	DATE 日 付	2020-5-18
	NOTE	
APPROVED DWG.No. 出 図 番 号		
DWG.No. KT3A-51H-P		
<b>VENN CO., LTD.</b> 株式会社		