

TD-8, 8A Type Temperature Regulating Valve

for **Hot Water Tank**, **Heat Exchanger**, **Heavy Oil Heater** etc.

High-performance single seat valve with pressure balancing structure and advantages of both single and double seat valves.

FEATURES

- Compact structure, large capacity.
- Single seat valve with less leakage.

SPECIFICATIONS

Utility	Heating		Cooling	
Model name	TD-8		TD-8A	
Type	Liquids	Gases	Liquids	Gases
Code name	TD8W-J □	TD8G-J	TD8AW-F	TD8AG-F
	※ 1, 2 or 3 for adjustment temperature range is required in □.			
Adjustment temperature range	1:40~60°C 2:60~80°C *1,*2 3:80~100°C		Adjustment temperature range is 20°C in breath between 40 and 100°C*2.	
Applicable ambient temperature	Setting temperature - 10°C or below			
Applicable fluid	Steam		Water	
Fluid to be heated or cooled	Water, oil & liquids	Gases	Water, oil & liquids	Gases
Seat type	Pressure balance type single seated			
Leakage allowance	0.05% or less than the rated flow			
End connection	Screwed JIS Rc (Union)			
Applicable temperature	Max. 184°C		Max. 60°C	
Length of capillary tube	2m(Available up to 5m)			
Materials	Body	Cast bronze		
	Disc & Seat	Stainless steel	Disc(Cast bronze), Seat(Brass)	
	Bellows	Phosphor bronze		
	Thermo bulb	Copper tube, Chrome plated	Copper tube, Copper with fin	Copper tube, Chrome plated
Applicable pressure for thermo bulb	Max. 1.0MPa			
Valve body pressure test	Hydraulic 1.5MPa			
Pressure limit at inlet	0.7MPa			

* 1. Other than the above adjustment temperature range are available upon your request. Refer to page 130.
 * 2. In case of liquid use, adjustable temperature range 100~120°C.(Withstanding temperature 130°C) is available upon your request.
 * 3. Refer to page 130 for adjustable temperature range.
 * 4. In case of liquid use, Thermo bulb with Stainless steel Max.3.0MPa is available upon your request.
 * 5. In case of liquid use, the protection cap for Thermo bulb, with non-standard(R1½" x L440, etc.), And the Teflon protection cap are available upon your request.

DIMENSIONS

(mm)

Size	L	G	H	d	Cv value	Mass(kg)
15(½")	136	30	378	½"	3	7
20(¾")	136	30	378	¾"	3	7
25(1")	142	33	378	1"	4	7
32(1¼")	184	40	391	1¼"	6.5	8.5
40(1½")	202	42	395	1½"	8	9

* Mass are for TD-8 Type

CONSTRUCTION

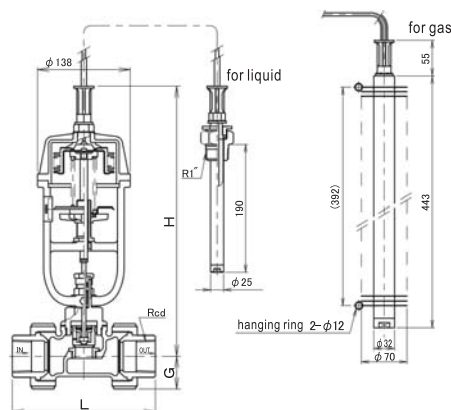

SIZE SELECTION CHART (for Steam)

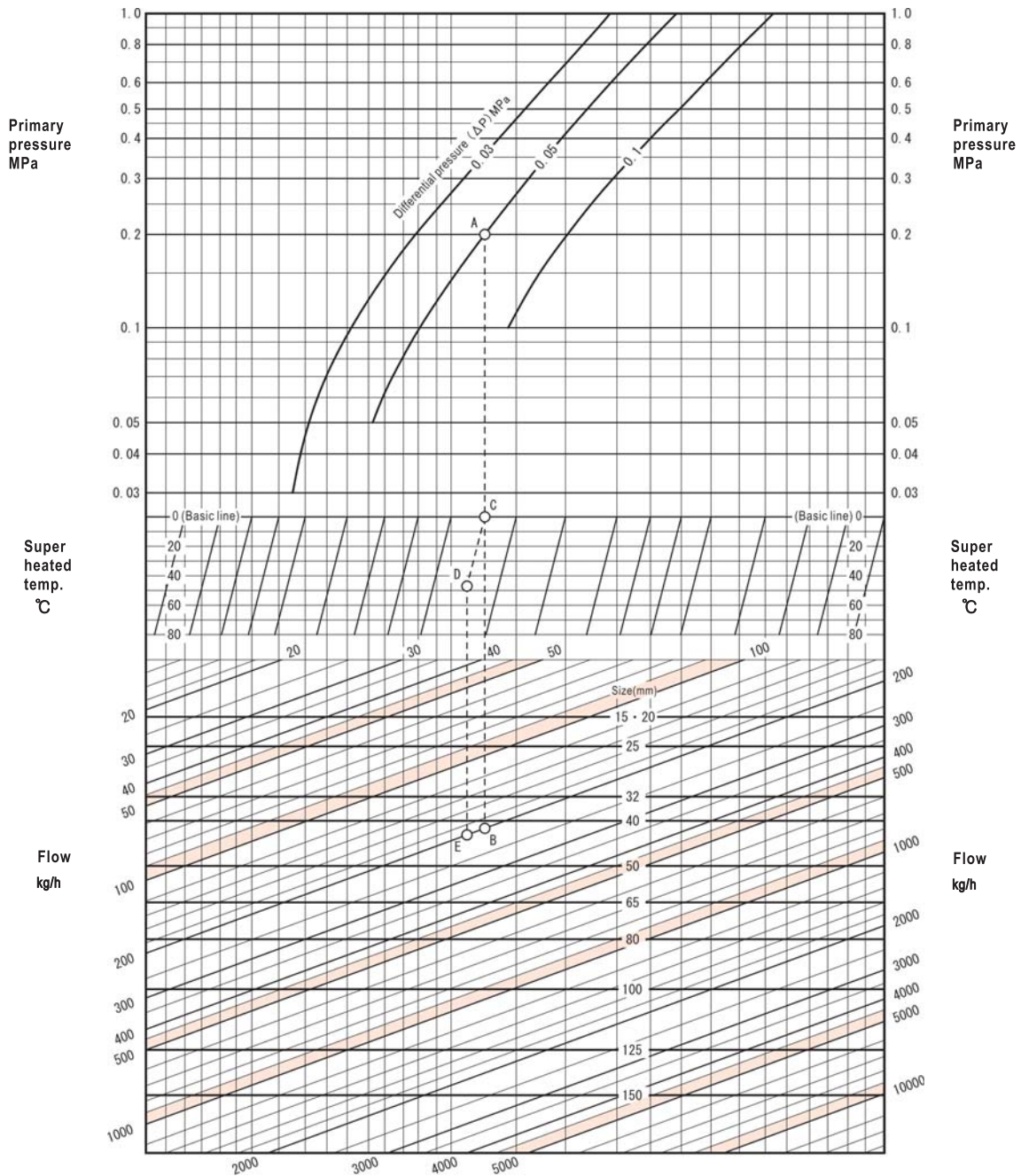

● HOW TO USE THE CHART

Select a valve with proper size for meeting the following requirements.

- Primary pressure: 0.2MPa
- Flow of saturated steam: 200kg/h
- Differential pressure: 0.05MPa

First, find out the point (A) where the primary pressure line (0.2MPa) intersects with the differential line (0.05MPa). Draw a vertical line from point A. This line intersects with flow curve (200kg/h). The intersection point is B. Since B is located between a nominal diameter range of 40mm~50mm. The larger value, which is 50mm is taken as the nominal diameter that we are looking for.

If the steam temperature is 180°C, the first thing is to calculate the degree of superheat.

Since degree of superheat = temperature of superheat steam - temperature of saturated steam, Degree of superheat: $180^{\circ}\text{C} - 132.9^{\circ}\text{C} = 47.1^{\circ}\text{C}$. Draw a vertical line from point A until it intersects with the benchmark line. The intersection point is named C. Move from point C parallel along the superheat line (47.1°C) to decide point D.

Draw a vertical line from point D until it intersects with flow curve (200kg/h). the intersection point is named E. Since point E is located between a nominal diameter range of 40mm~50mm. The larger value, which is 50mm is taken as the nominal diameter that we are looking for.

See page 263 for temperature of saturated steam.

DATA/Temperature Regulating Valve

Key Points for Installation

PIPING EXAMPLE

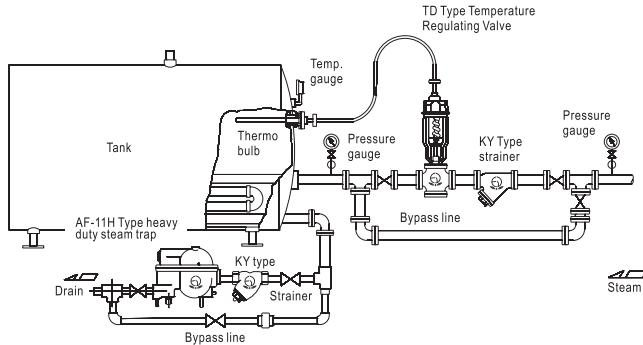
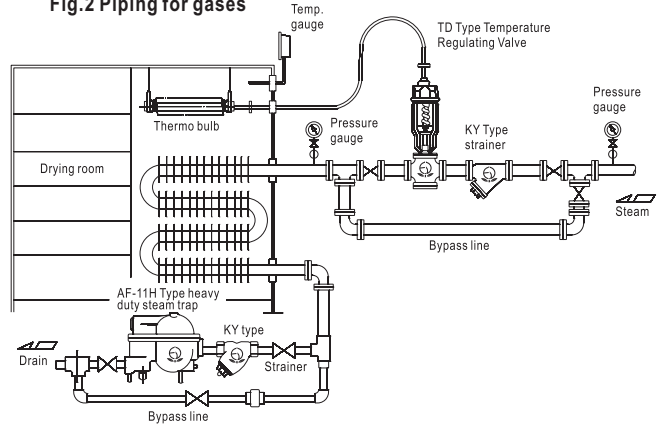
Fig.1 Piping for liquids

Fig.2 Piping for gases

KEY POINTS FOR SELECTION AND INSTALLATION

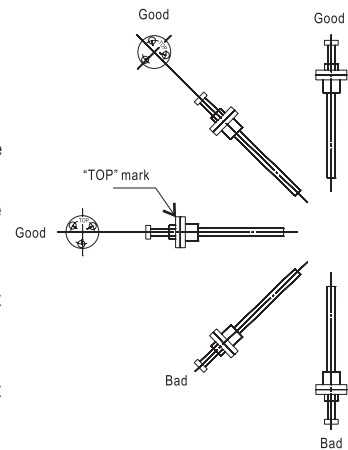
- Temperature regulating may not be possible if ambient temperature is very high due to direct sunlight or heat accumulated in the place where the valve is installed. The following is the allowed ambient temperature for different types of valves.
 ※Allowed ambient temperature:
 TD-□ (for heating), TD-□A (for cooling): -10°C or below.
 TD-□L (for low temperature heating), TD-□AL (low temperature cooling): $+20^{\circ}\text{C}$ or below.
- Generally, for the purpose of selecting size of valve, the differential pressure before and after valve should be 0.05MPa. In addition, the inlet pressure of temperature regulating valve should be 0.2~0.3MPa. Such a pressure can help ensuring stable temperature regulating performance and expanding the service life of the valve.
- For ideal controllability, take the median of the temperature regulating range as set temperature.
- For applications with low capacity and risk of leakage, select single seat TD-8 or TD-4 series that have less leakage.
- Install strainer at the primary side of temperature regulating valve.
- For equipments which operation cannot be stopped, install bypass piping (with stop valve) between the primary and secondary sides of temperature regulating valve (see Fig.1, 2). If such a bypass piping is not installed, install blowing stop valve, which is branched from the main pipe, right before the primary stop valve of temperature regulating valve to make flushing possible.
- The temperature may exceed set temperature due to leakage of temperature regulating valve. To avoid such increase of temperature, install electric valve or other blocking devices at the outlet side of temperature regulating valve.
- Make sure the direction of flow of fluid is the same as the direction marked on the product and install temperature regulating valve vertically to horizontal pipes.
- Install stop valve and pressure gauge before and after temperature regulating valve (see Fig.1, 2).
- The thermo bulb should be installed in a manner so that the head faces horizontally or slightly downwardly (but not upwardly).
 In addition, the "TOP" mark must face upwardly (see Fig.3).
- The thermo bulb must have at least 3/4 of its total length submerged into the flowing fluid. The thermometer must be installed nearing and at the same height of the thermo bulb.
- Do not bend the capillary tube in an acute angle.
- If the fluid is steam, install steam trap for discharging drain generated by heat exchanger.
- Leave sufficient space for dismantling and maintenance purpose.
- Temperature regulating valve should be supported and fixed properly to avoid impact due to the weight of piping, bending force, or vibration.
- In case of any freezing possibility, insulate or drain out.
- Deviation of temperature setting and range of temperature regulating are as below:

Fig.3 Direction for installation of thermo bulb

TEMPERATURE SET ERROR

Length of capillary tube	Heating & cooling		Low temp Heating & cooling
	A	B	
2m	$\pm 2^{\circ}\text{C}$	$\pm 3^{\circ}\text{C}$	$\pm 3.5^{\circ}\text{C}$ 2m or longer add $\pm 0.5^{\circ}\text{C}$ per 1m
2~3.5m	$\pm 2.5^{\circ}\text{C}$	$\pm 3.5^{\circ}\text{C}$	
3.5~5m	$\pm 3^{\circ}\text{C}$	$\pm 4^{\circ}\text{C}$	

* 1. A: In case of Max. 100°C or less for adjustable temperature range.
 B: In case of exceeding 100°C in all or part of adjustable temperature range.
 * 2. In case of Gases service, $\pm 1^{\circ}\text{C}$ is added.

ADJUSTABLE TEMPERATURE RANGE

Code No.	Heating & cooling		Low temp Heating & cooling	
	Adjustable temp. Range	Withstanding temperature	Adjustable temp. Range	Withstanding temperature
1	40~60 $^{\circ}\text{C}$	70 $^{\circ}\text{C}$	15~35 $^{\circ}\text{C}$	50 $^{\circ}\text{C}$
	50~70 $^{\circ}\text{C}$	80 $^{\circ}\text{C}$	20~40 $^{\circ}\text{C}$	
	60~80 $^{\circ}\text{C}$	90 $^{\circ}\text{C}$	35~55 $^{\circ}\text{C}$	70 $^{\circ}\text{C}$
2	70~90 $^{\circ}\text{C}$	100 $^{\circ}\text{C}$		
	80~100 $^{\circ}\text{C}$	110 $^{\circ}\text{C}$		

* Other than the above temperature range items are available upon your request.